

Source: Public Works

Joh

Agenda Item No: Item (B)

To: City Council
From: City Manager and Staff

MM

Council Meeting Date: Mar 5, 2012

Public Hearing- Forum Boulevard Left Turn Lanes into MKT Parking and Victoria Place

Re:

EXECUTIVE SUMMARY:

Staff has prepared for Council consideration a resolution setting a public hearing for March 19, 2012 concerning the addition of a left turn lane on Forum Boulevard into the Victoria Park driveway and the MKT driveway. See attached location map (Exhibit 1). The funding shown in the CIP for this project is \$200,000 from the Capital Fund Balance. This project has been identified for construction in 2012. An interested parties meeting was held on January 24, 2012 at the Country Club of Missouri. More than 100 interested people attended the meeting.

DISCUSSION:

At the July 5, 2011 council meeting, staff presented a report addressing two topics; CM 3319 concerning analysis of the need for left turn lanes on Forum Boulevard at Victoria Park driveway, MKT driveway and Wilson's Fitness driveway, and CM 2867 concerning converting the Wilson's Fitness driveway to right-in right-out. Council directed staff to conduct interested party meetings for an access management project on Forum Boulevard between the Wilson's Fitness driveway and Shoreside Drive, and to budget a CIP project for left turn lanes on Forum Boulevard at the Victoria Park and MKT driveways.

An interested parties meeting was held on January 24, 2012 at the Country Club of Missouri. More than 100 people attended the meeting. The information presented at the meeting included an access management plan which consisted of two phases. The first phase consists of constructing left turn lanes into the Victoria Park and MKT driveways, and the second phase consists of a future project to construct a pedestrian bridge over Hinkson Creek to allow better pedestrian facilities along Forum Boulevard with access to the MKT trail. The future pedestrian bridge will allow re-striping Forum Boulevard on the bridge to provide a left turn lane into Wilson's Fitness.

This public hearing is for Forum Boulevard left turn lanes into the Victoria Park and MKT driveways as shown on the attached Exhibit 2. The existing shoulders on Forum Boulevard are not adequate for vehicle lane loads. The proposal is to reconstruct the existing shoulders to accommodate vehicle loads and to repaint the lane markings to include the left turn lanes. The existing Forum Boulevard cross section and the proposed cross section with the left turn lanes at the Victoria Park and MKT driveways is shown on the attached Exhibit 3. The the proposed shoulder reconstruction is within the existing shoulder area therefore easements will not be needed. The shoulder reconstruction and installation of the left turn lane will accommodate the future pedestrian bridge and two way side path connection to the MKT trail which is a proposed GetAbout project (see Exhibit 4). The future GetAbout project will have a public hearing at a later date.

Utility Coordination:

The proposed improvement consists of repaving portions of the the existing shoulder to accommodate traffic loads and therefore not expected to impact existing utilities. Utility coordination began with initial survey and will continue through final plan design and construction.

FISCAL IMPACT:

\$200,000 has been appropriated for the construction of Forum Boulevard left turn lanes into the Victoria Park and MKT driveways.

VISION IMPACT:

<http://www.gocolumbiamo.com/Council/Meetings/visionimpact.php>

Columbia and central Missouri, a growing urban community, will have a modern transportation system, which allows its citizens to move about freely within the region using whatever means are desired "automobile, bus, bicycle, walking" and to do so safely, within a reasonable time frame, and without encountering needless congestion.

A network of safe roadways in and around the City will provide sustainable, efficient mobility to vehicular travel and other modes in a complimentary manner.

Maximize the capacity of existing roadway systems by having the City and County adopt and implement programs for traffic signal optimization, intersection improvements, turn lanes, effective access management, and etc.

SUGGESTED COUNCIL ACTIONS:

Following public input and Council discussion, Council should make a motion directing staff to proceed with plans and specifications for construction of Forum Boulevard left turn lanes into the Victoria Park and MKT driveways.

FISCAL and VISION NOTES:					
City Fiscal Impact Enter all that apply		Program Impact		Mandates	
City's current net FY cost	\$686.00	New Program/ Agency?	No	Federal or State mandated?	No
Amount of funds already appropriated	\$200,000.00	Duplicates/Epands an existing program?	No	Vision Implementation impact	
Amount of budget amendment needed	\$0.00	Fiscal Impact on any local political subdivision?	No	Enter all that apply: Refer to Web site	
Estimated 2 year net costs:		Resources Required		Vision Impact?	Yes
One Time	\$0.00	Requires add'l FTE Personnel?	No	Primary Vision, Strategy and/or Goal Item #	#13
Operating/ Ongoing	\$0.00	Requires add'l facilities?	No	Secondary Vision, Strategy and/or Goal Item #	#13.3/13.3.4
		Requires add'l capital equipment?	No	Fiscal year implementation Task #	Unknown

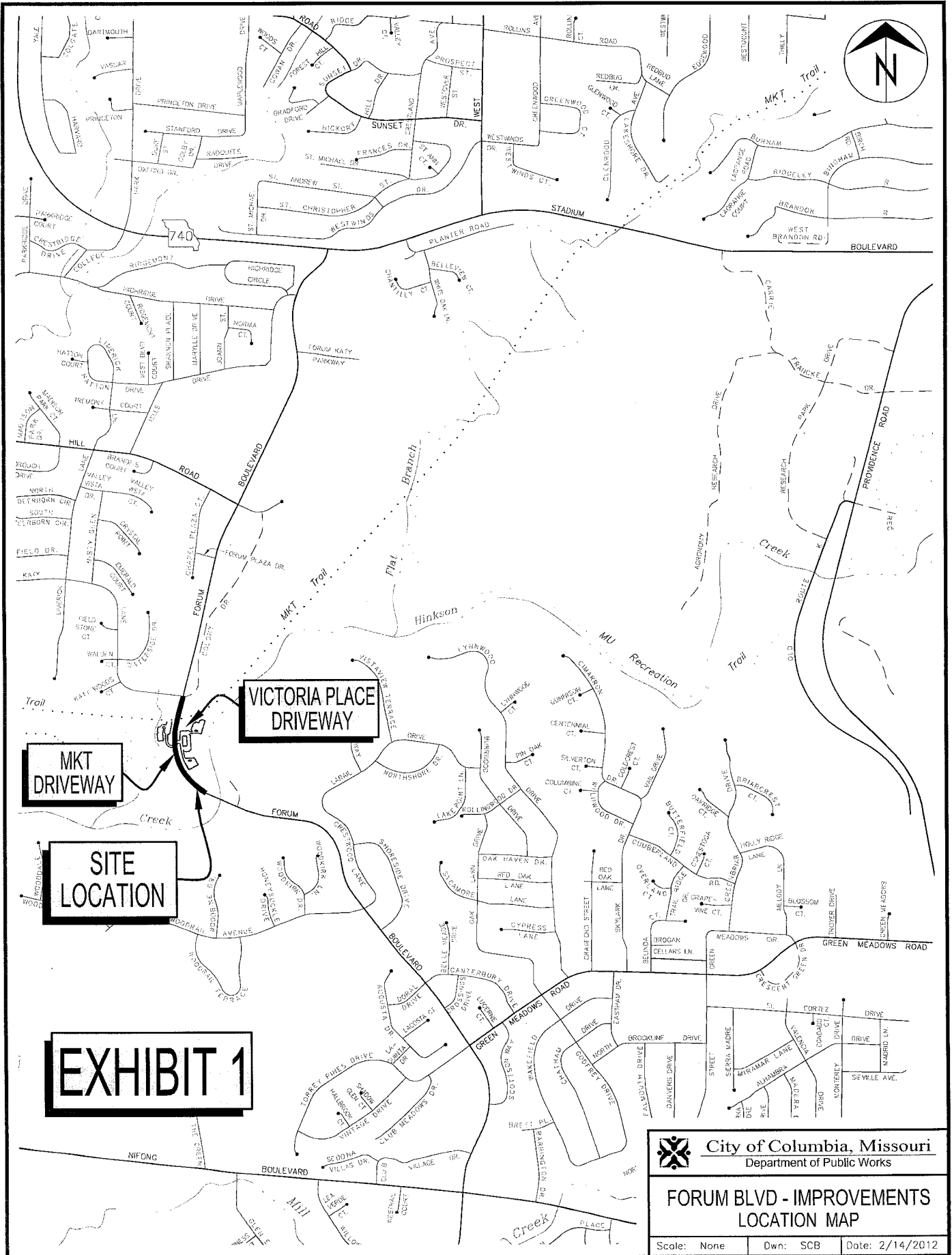

City of Columbia, Missouri
 Department of Public Works

**FORUM BLVD - IMPROVEMENTS
 LOCATION MAP**

Scale: None	Own: SCB	Date: 2/14/2012
-------------	----------	-----------------

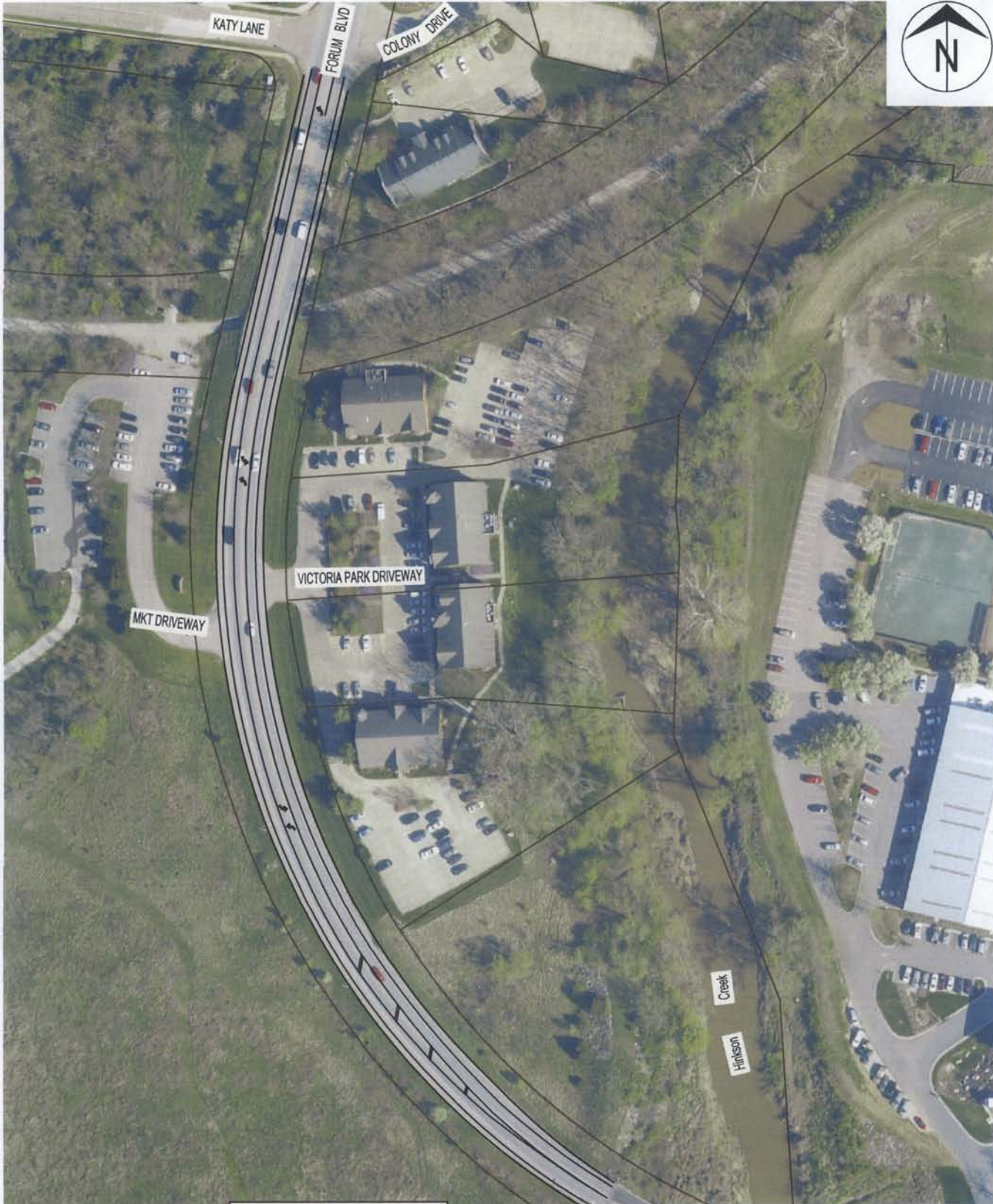

EXHIBIT 2



City of Columbia, Missouri
Department of Public Works

FORUM BOULEVARD LEFT TURNS AT VICTORIA PLACE & MKT

Scale: 1"=130' Dwn: SCB Date: 2/14/12

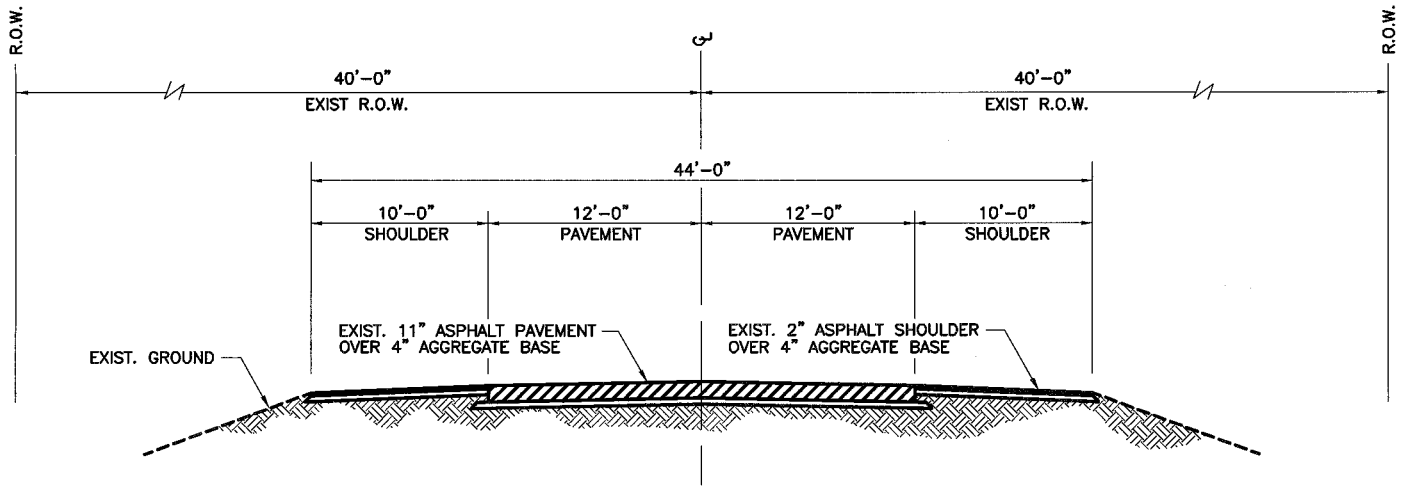

EXISTING TYPICAL SECTION
(NOT TO SCALE)

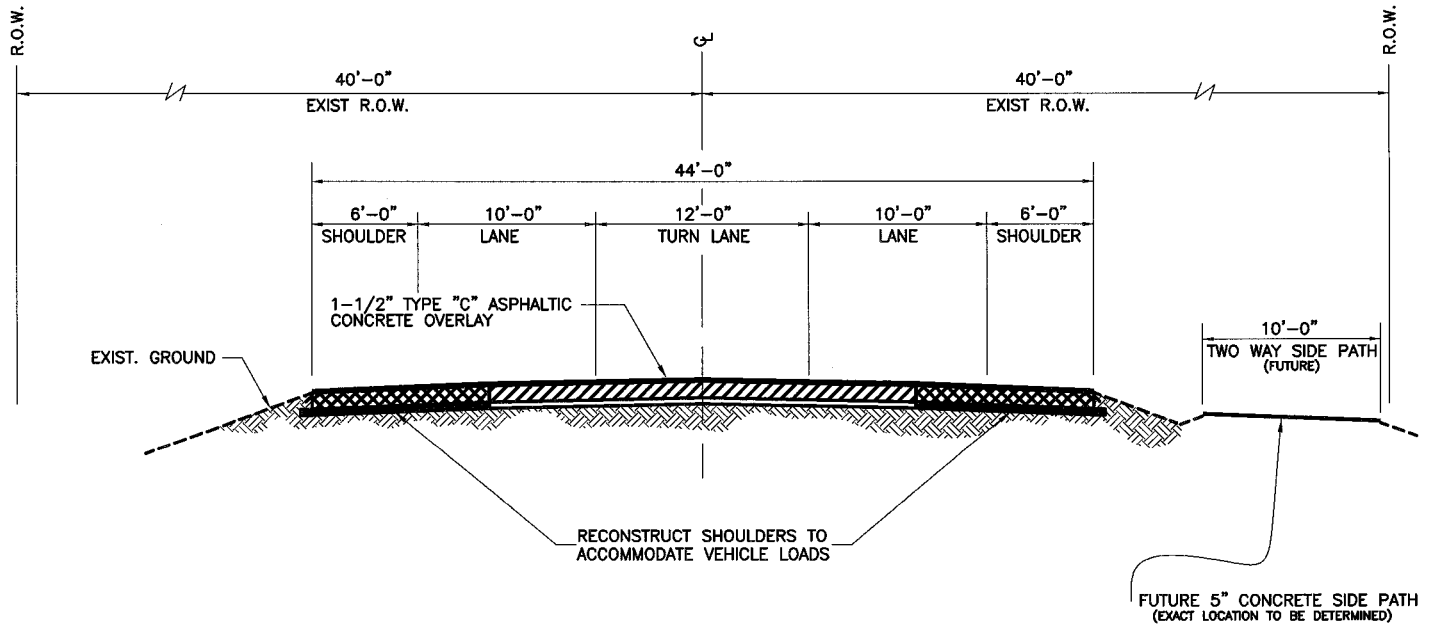

PROPOSED TYPICAL SECTION
(NOT TO SCALE)

EXHIBIT 3

City of Columbia, Missouri
 Department of Public Works

FORUM BLVD - IMPROVEMENTS
TYPICAL SECTIONS

Scale: None	Dwn: SCB	Date: 2/14/2012
-------------	----------	-----------------



EXHIBIT 4

 City of Columbia, Missouri
Department of Public Works

FORUM BOULEVARD LANE MODIFICATION AND BIKE PATH

Scale: 1"=200' Dwn: SCB Date: 2/14/12

A RESOLUTION

declaring the necessity for the construction of street improvements to widen Forum Boulevard from Katy Lane to the bridge over Hinkson Creek to accommodate left turn movements from Forum Boulevard into the Victoria Park driveway and MKT driveway; stating the nature of and the estimate of the cost of the improvement; providing for payment for the improvement; providing for compliance with the prevailing wage law; and setting a public hearing.

BE IT RESOLVED BY THE COUNCIL OF THE CITY OF COLUMBIA, MISSOURI, AS FOLLOWS:

SECTION 1. The City Council deems the construction of street improvements and other miscellaneous work, all in accordance with the City of Columbia Street and Storm Sewer Specifications and Standards, specifically to include the widening of Forum Boulevard to add a traffic lane from Katy Lane to the bridge over Hinkson Creek to accommodate left turn movements from Forum Boulevard into the Victoria Park driveway and MKT driveway, necessary to the welfare and improvement of the City.

SECTION 2. The nature and scope of the improvement shall consist of furnishing all labor, materials, transportation, insurance and all other items, accessories and incidentals thereto necessary for the complete construction of the improvements.

SECTION 3. The estimated cost of this improvement is \$200,000.00.

SECTION 4. Payment for this improvement shall be made from Capital Improvement Sales Tax Funds and such other funds as may be lawfully appropriated.

SECTION 5. Any work done in connection with the construction of the improvement specified above shall be in compliance with the provisions of the prevailing wage laws of the State of Missouri.

SECTION 6. A public hearing in respect to this improvement will be held in the Council Chamber of the City Hall Building, 701 E. Broadway, Columbia, Missouri, at 7:00 p.m. on March 19, 2012. The City Clerk shall cause notice of this hearing to be published in a newspaper published in the City.

ADOPTED this _____ day of _____, 2012.

ATTEST:

City Clerk

Mayor and Presiding Officer

APPROVED AS TO FORM:

City Counselor